

MC1G-525C(F)

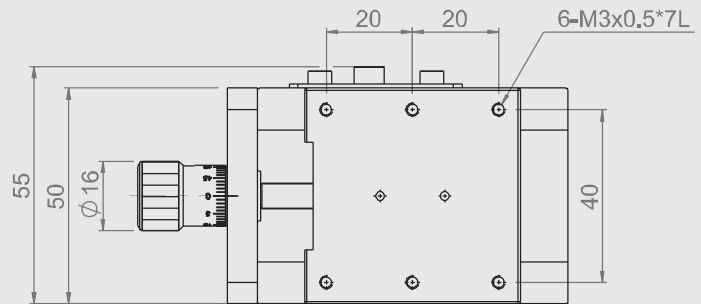

Knob type :

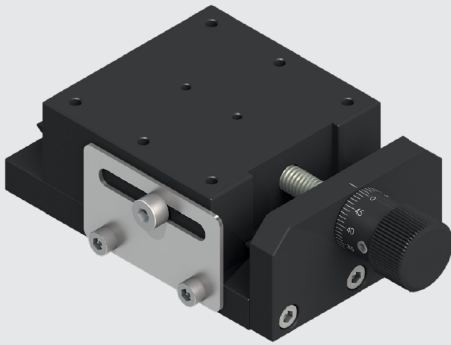
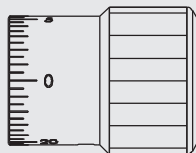

MC1G-525F(Fit PITCH0.25)

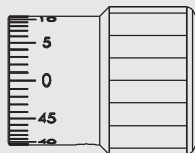
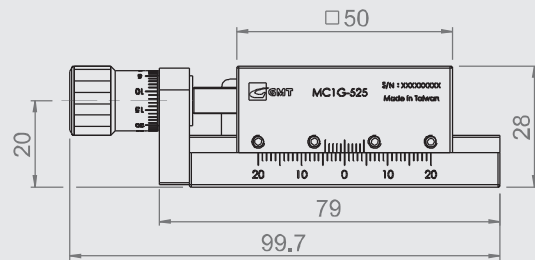

MC1G-525C(Fit PITCH0.5)

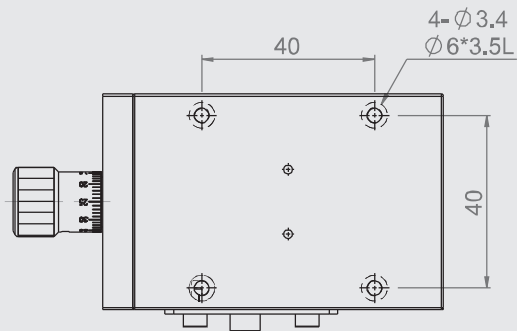

Specification

Unit: mm

Model no.	Table size	Base dimensions	Adjustment structure			Straightness accuracy	Parallel	Dynamic Parallel	Allowable Loading (kgf)	Weight kg	Material	Surface finish
			Movement per knob cycle	Knob mini. Reading	Travel stroke							
MC1G-525C	50*50	50*79	0.5	0.01/div.	±11	0.03	0.05	0.04	5	0.27	Aluminum alloy	Black anodized
MC1G-525F			0.25	0.005/div.								